

REV.	DATE	REVISION DESCRIPTION	PON. NO.
06	FEB 05	NEW	05-01

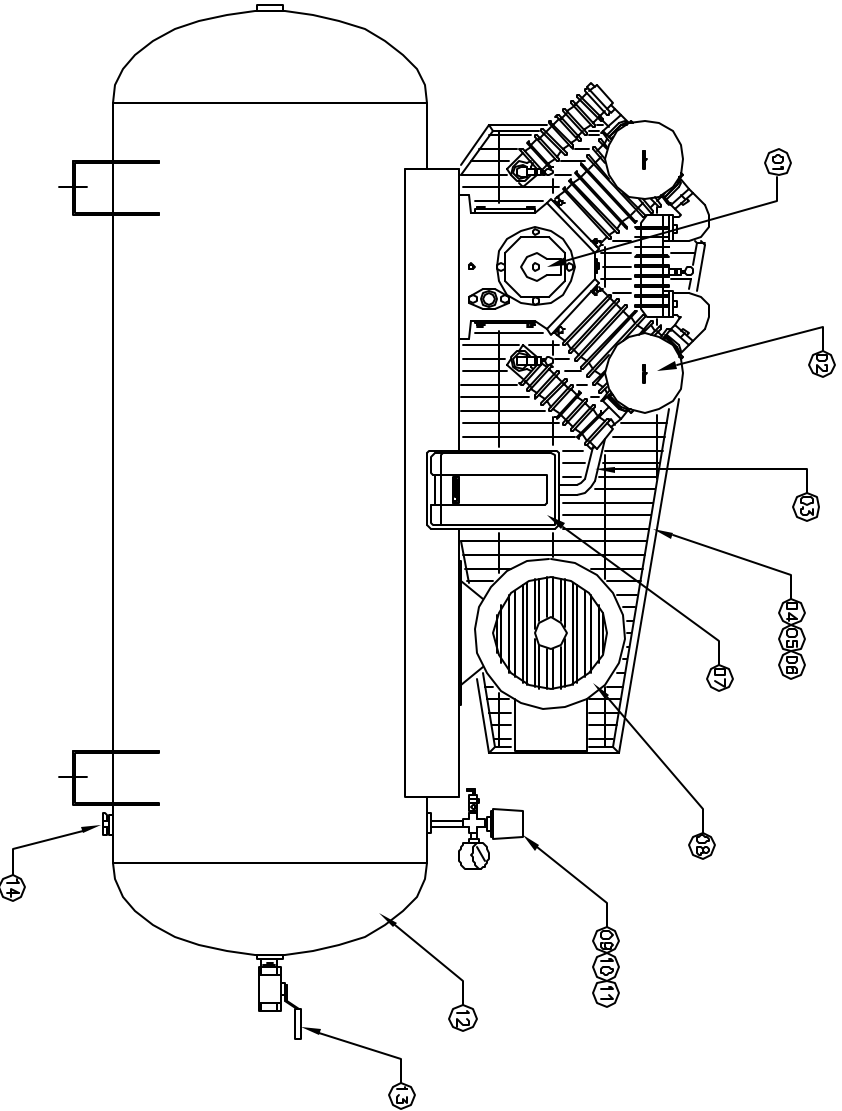

ITEM	PART NUMBER	QTY	DESCRIPTION
01	DEV-100	1	PUMP ASSEMBLY
02	PB-21176001	2	INTAKE FILTER ASSEMBLY
03	PB-21177013	2	INTAKE FILTER ELEMENT
04	GT-9748	1	AFTERCoolER TUBE
05	EG-9492	1	BELT GUARD ASSEMBLY
06	PL-9196	1	MOTOR PULLEY (B.1 PO. 1 1/2" BORE, 2B)
07	BT-9038	2	DRIVE BELT (887)
08	MS-340-43	1	STARTER 200/208-60-3
09	MS-340-43	1	STARTER 230-60-3
10	MS-340-45	1	STARTER 480-60-3
11	MS-340-69	1	STARTER 575-60-3
12	MD-6614	1	MOTOR 200/208-60-3
13	MD-6635	1	MOTOR 230-60-3
14	MD-6635	1	MOTOR 460-60-3
15	MD-6613	1	MOTOR 575-60-3
16	SSS-9003U15150	1	PRESSURE SWITCH
17	GA-250	1	PRESSURE GAUGE
18	TIA-5200	1	SAFETY VALVE 200 PSI
19	TA-9463-1	1	TANK - 120 GAL. HORIZ.
20	VA-8705	1	BALL VALVE
21	SS-2707	1	DRAIN VALVE
22	CCV-9405	1	CHECK VALVE (NOT SHOWN)

IMPORTANT NOTE: This print is the confidential property of DEVAIR, INC. It is not to be used or reproduced in any manner, nor submitted to other parties for examination without the prior approval of DEVAIR, INC.

FRACTIONAL DIMENSIONS: 1/32
 DECIMAL DIMENSION: 2,1005
 UNLESS OTHERWISE SPECIFIED



NAME OF PROJECT		DESCRIPTION OF DRAWING	
10 HP INDUSTRIAL STANDARD UNIT C/W 'DEV-100' PUMP		COMPRESSOR OUTFIT	
DRAWN BY	CHECKED BY	DATE	SCALE
W/BLDM		09FEB 05	N.T.S.
		DRAWING NO.	SHT NO/REV
		IS10-100120	

REV.	DATE	REVISION DESCRIPTION	PON. NO.
0	08/28/05	NEW	05-04

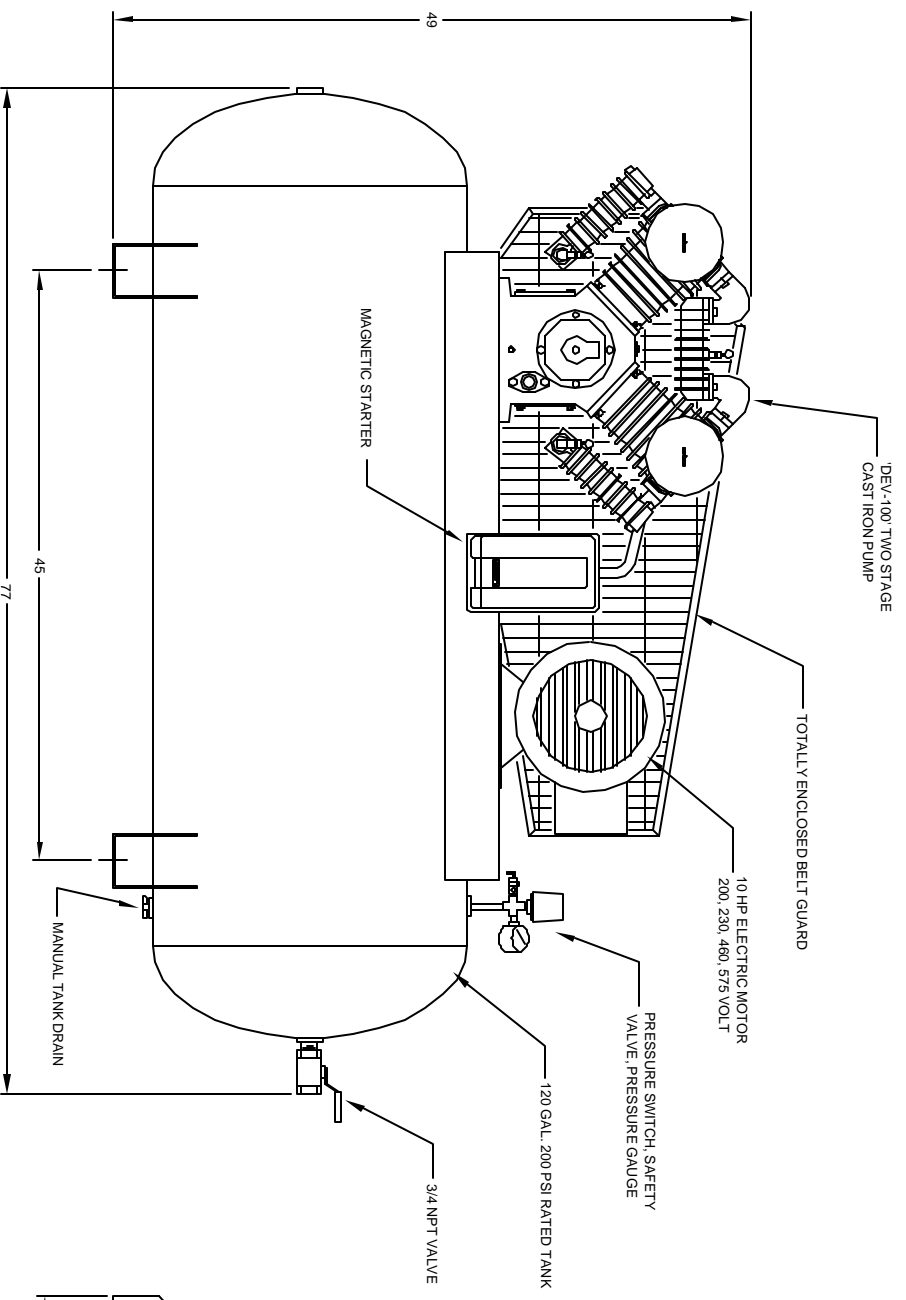

COMPRESSOR OUTPUT DATA				PRESSURE SETTINGS				RECEIVER CAPACITY		COMPRESSOR PUMP DATA				WEIGHT		ELECTRICAL					
MODEL	HP	DISPL. SCFM	DEL'Y SCFM	PSIG	KPA	GAL.	LITRS	TYPE	CYCL.	STAGE	RRM	LB.	KG.	VOLTAGE	FL.A.	FL.A.	FL.A.	FL.A.			
IS10-100120	10	43	30	150	1035	120	454	DEV-100	4	2	780	840	427	200/3	31	230/3	28	480/3	14	575/3	11

IMPORTANT NOTE: This print is the confidential property of DEVAIR, INC. It is not to be used or reproduced in any manner, nor submitted to other parties for examination without the prior approval of DEVAIR, INC.

FRACTIONAL DIMENSIONS: 1/32 DECIMAL DIMENSION: 2, 1005 UNLESS OTHERWISE SPECIFIED								NAME OF PROJECT: _____				DESCRIPTION OF DRAWING: _____			
10 HP, 120 GAL., 150 PSI PRESSURE DRAWN BY: _____ W/BLM								CHECKED BY: _____ DATE: 08/28/05				SCALE: N.T.S.			